

管用圓柱螺紋的基本牙形、公式及基準尺寸

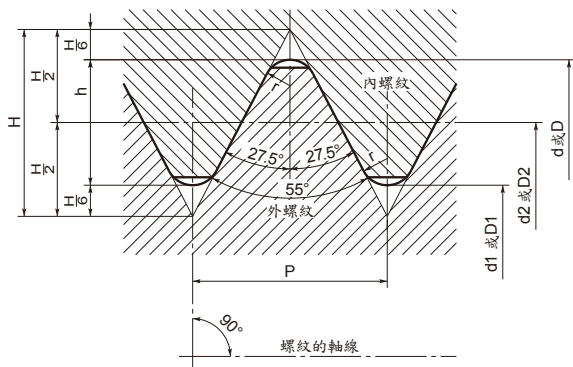

$$P = \frac{25.4}{n}$$

$$H = 0.960491 P$$

$$h = 0.640327 P$$

$$r = 0.137329 P$$

$$d_2 = d - h \quad D_2 = d_2$$

$$d_1 = d - 2h \quad D_1 = d_1$$

單位：mm

螺紋公稱直徑	螺牙數 (每 25.4 mm) n	節距 P (參考)	螺牙高度 h	螺牙頂部及 底部的圓角 r	外螺紋		
					外徑 d	有效直徑 d ₂	根部直徑 d ₁
					內螺紋		
					根部直徑 D	有效直徑 D ₂	內徑 D ₁
G 1/16	28	0.9071	0.581	0.12	7.723	7.142	6.561
G 1/8	28	0.9071	0.581	0.12	9.728	9.147	8.566
G 1/4	19	1.3368	0.856	0.18	13.157	12.301	11.445
G 3/8	19	1.3368	0.856	0.18	16.662	15.806	14.950
G 1/2	14	1.8143	1.162	0.25	20.955	19.793	18.631
G 5/8	14	1.8143	1.162	0.25	22.911	21.749	20.587
G 3/4	14	1.8143	1.162	0.25	26.441	25.279	24.117
G 7/8	14	1.8143	1.162	0.25	30.201	29.039	27.877
G1	11	2.3091	1.479	0.32	33.249	31.770	30.291
G1 1/8	11	2.3091	1.479	0.32	37.897	36.418	34.939
G1 1/4	11	2.3091	1.479	0.32	41.910	40.431	38.952
G1 1/2	11	2.3091	1.479	0.32	47.803	46.324	44.845
G1 3/4	11	2.3091	1.479	0.32	53.746	52.267	50.788
G2	11	2.3091	1.479	0.32	59.614	58.135	56.656
G2 1/4	11	2.3091	1.479	0.32	65.710	64.231	62.752
G2 1/2	11	2.3091	1.479	0.32	75.184	73.705	72.226
G2 3/4	11	2.3091	1.479	0.32	81.534	80.055	78.576
G3	11	2.3091	1.479	0.32	87.884	86.405	84.926
G3 1/2	11	2.3091	1.479	0.32	100.330	98.851	97.372
G4	11	2.3091	1.479	0.32	113.030	111.551	110.072
G4 1/2	11	2.3091	1.479	0.32	125.730	124.251	122.772
G5	11	2.3091	1.479	0.32	138.430	136.951	135.472
G5 1/2	11	2.3091	1.479	0.32	151.130	149.651	148.172
G6	11	2.3091	1.479	0.32	163.830	162.351	160.872