

內六角螺栓的形狀和尺寸

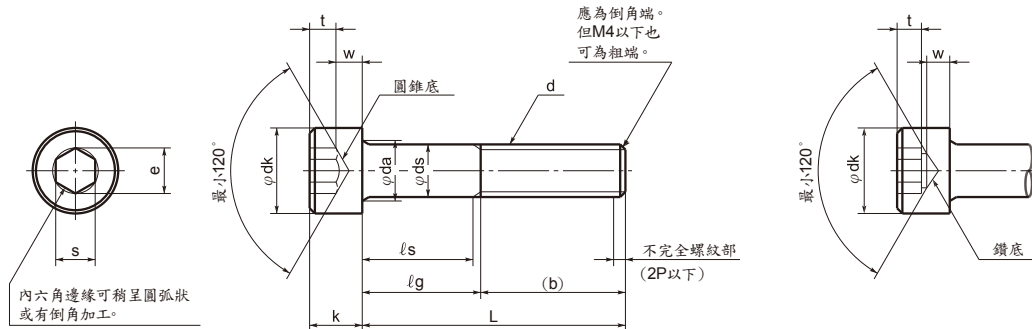

單位：mm

螺紋公稱直徑 (d)	M2	M2.5	M3	M4	M5	M6	M8	M10	M12	M16	M20	M24
螺距	0.4	0.45	0.5	0.7	0.8	1	1.25	1.5	1.75	2	2.5	3
b * 1 (參考)	16	17	18	20	22	24	28	32	36	44	52	60
dk	最大 * 2 3.8	4.5	5.5	7	8.5	10	13	16	18	24	30	36
	最大 * 3 3.98	4.68	5.68	7.22	8.72	10.22	13.27	16.27	18.27	24.33	30.33	36.39
	最小 3.62	4.32	5.32	6.78	8.28	9.78	12.73	15.73	17.73	23.67	29.67	35.61
da	最大 2.6	3.1	3.6	4.7	5.7	6.8	9.2	11.2	13.7	17.7	22.4	26.4
ds	最大 2	2.5	3	4	5	6	8	10	12	16	20	24
	最小 1.86	2.36	2.86	3.82	4.82	5.82	7.78	9.78	11.73	15.73	19.67	23.67
e	最小 * 4 * 5 1.733	2.303	2.873	3.443	4.583	5.723	6.863	9.149	11.429	15.996	19.437	21.734
k	最大 2	2.5	3	4	5	6	8	10	12	16	20	24
	最小 1.86	2.36	2.86	3.82	4.82	5.70	7.64	9.64	11.57	15.57	19.48	23.48
r	最小 0.1	0.1	0.1	0.2	0.2	0.25	0.4	0.4	0.6	0.6	0.8	0.8
s * 5	公稱直徑 1.5	2	2.5	3	4	5	6	8	10	14	17	19
	最大 1.58	2.08	2.58	3.08	4.095	5.14	6.14	8.175	10.175	14.212	17.23	19.275
	最小 1.52	2.02	2.52	3.02	4.02	5.02	6.02	8.025	10.025	14.032	17.05	19.065
t	最小 1	1.1	1.3	2	2.5	3	4	5	6	8	10	12
v	最大 0.2	0.25	0.3	0.4	0.5	0.6	0.8	1	1.2	1.6	2	2.4
dw	最小 3.48	4.18	5.07	6.53	8.03	9.38	12.33	15.33	17.23	23.17	28.87	34.81
w	最小 0.55	0.85	1.15	1.4	1.9	2.3	3.3	4	4.8	6.8	8.6	10.4

\* 1 適用於粗階梯線之間沒有陰影的數值。

\* 2 適用於沒有滾花的頭部。

\* 3 適用於有滾花的頭部。

\* 4  $e_{min} = 1.14 s_{min}$

\* 5 六角孔的尺寸 s 及 e 的儀錶檢查依據 JIS B 1016。

單位：mm

螺紋公稱直徑 (d)			M2		M2.5		M3		M4		M5		M6		M8		M10		M12		M16		M20		M24					
L *			ls 及 lg																											
公稱直徑 長度	min		max		ls	lg	ls	lg	ls	lg	ls	lg	ls	lg	ls	lg	ls	lg	ls	lg	ls	lg	ls	lg	ls	lg	ls	lg		
	min	max	min	max	min	max	min	max	min	max	min	max	min	max	min	max	min	max	min	max	min	max	min	max	min	max	min	max		
3	2.8	3.2																												
4	3.76	4.24																												
5	4.76	5.24																												
6	5.76	6.24																												
8	7.71	8.29																												
10	9.71	10.29																												
12	11.65	12.35																												
16	15.65	16.35																												
20	19.58	20.42	2	4																										
25	24.58	25.42			5.75	8	4.5	7																						
30	29.58	30.42					9.5	12	6.5	10	4	8																		
35	34.5	35.5							11.5	15	9	13	6	11																
40	39.5	40.5							16.5	20	14	18	11	16	5.75	12														
45	44.5	45.5									19	23	16	21	10.75	17	5.5	13												
50	49.5	50.5									24	28	21	26	15.75	22	10.5	18												
55	54.4	55.6											26	31	20.75	27	15.5	23	10.25	19										
60	59.4	60.6											31	36	25.75	32	20.5	28	15.25	24										
65	64.4	65.6													30.75	37	25.5	33	20.25	29	11	21								
70	69.4	70.6													35.75	42	30.5	38	25.25	34	16	26								
80	79.4	80.6													45.75	52	40.5	48	35.25	44	26	36	15.5	28						
90	89.3	90.7															50.5	58	45.25	54	36	46	25.5	38	15	30				
100	99.3	100.7															60.5	68	55.25	64	46	56	35.5	48	25	40				
110	109.3	110.7																	65.25	74	56	66	45.5	58	35	50				
120	119.3	120.7																	75.25	84	66	76	55.5	68	45	60				
130	129.2	130.8																			76	86	65.5	78	55	70				
140	139.2	140.8																				86	96	75.5	88	65	80			
150	149.2	150.8																					96	106	85.5	98	75	90		
160	159.2	160.8																					106	116	95.5	108	85	100		
180	179.2	180.8																							115.5	128	105	120		
200	199.075	200.925																							135.5	148	125	140		

\*一般使用的標準長度範圍在粗階梯線之間。帶有陰影的數值為全螺紋，頭部的不完全螺紋部長度應在 3P 以內。

沒有陰影的數值表示 lg 及 ls 的值，可用下式求出。

$$lg \max = l \text{ nom} - b \cdot ls \min = lg \max - 5P$$