

六角螺帽 (不依據 ISO 4032 ~ 4036 及 ISO 8673 ~ 8675 的六角螺母) 引用自 JIS B 1181:2009

Hexagon Nuts

六角螺帽的形狀和尺寸

加工程度：中 (不到 M6 時加工程度為：上)

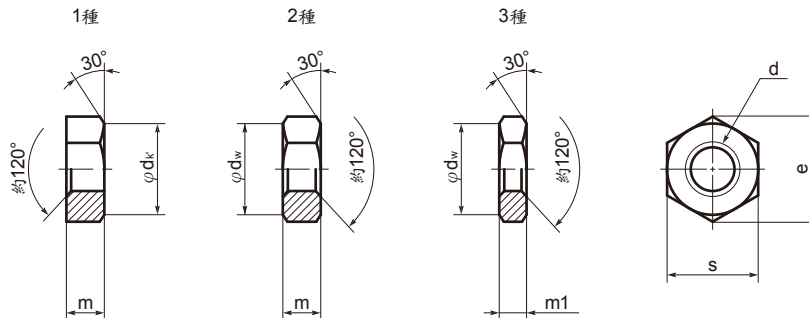

單位：mm

螺紋公稱直徑 (d)		m		m1		s		e	$\phi dw \cdot \phi dk'$
粗牙	細牙	基準尺寸	容許偏差	基準尺寸	容許偏差	基準尺寸	容許偏差	約	約
M2	—	1.6		1.2		4		4.6	3.8
M2.5	—	2	0	1.6		5		5.8	4.7
M3	—	2.4	-0.25	1.8		5.5		6.4	5.3
(M3.5)	—	2.8		2	-0.25	6		6.9	5.8
M4	—	3.2		2.4		7	-0.2	8.1	6.8
M5	—	4	-0.30	3.2	0 -0.3	8		9.2	7.8
M6	—	5	0	3.6		10	0 -0.6	11.5	9.8
(M7)	—	5.5	-0.48	4.2		11		12.7	10.8
M8	M8x 1	6.5		5	-0.48	13	0	15	12.5
M10	M10x 1.25	8	0	6		17	-0.7	19.6	16.5
M12	M12x 1.25	10	-0.58	7		19		21.9	18
(M14)	(M14x 1.5)	11		8	0	22		25.4	21
M16	M16x 1.5	13	0	10	-0.58	24	0	27.7	23
(M18)	(M18x 1.5)	15	-0.70	11		27	-0.8	31.2	26
M20	M20x 1.5	16		12		30		34.6	29
(M22)	(M22x 1.5)	18		13	0	32		37	31
M24	M24x 2	19		14	-0.70	36		41.6	34
(M27)	(M27x 2)	22	0	16		41	0	47.3	39
M30	M30x 2	24	-0.84	18		46	-1.0	53.1	44
(M33)	(M33x 2)	26		20		50		57.7	48
M36	M36x 3	29		21		55		63.5	53
(M39)	(M39x 3)	31		23	0	60		69.3	57
M42		34		25	-0.84	65	0	75	62
(M45)		36	0	27		70	-1.2	80.8	67
M48		38	-1.0	29		75		86.5	72
(M52)		42		31		80		92.4	77
M56		45		34	0	85		98.1	82
(M60)		48		36	-1.0	90	0	104	87
M64		51	0 -1.2	38		95	-1.4	110	92

備註：儘量不使用帶有括弧的螺紋公稱直徑。