

SRT0610

Shaft dia. (軸徑) $\phi 6$ Lead (導程) 10mm

Ct7&Ct10

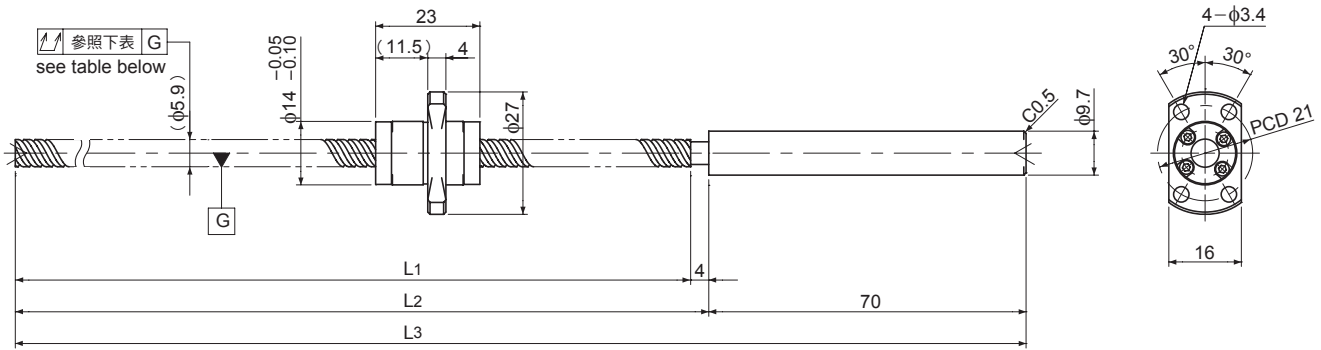

Unit (單位) : mm

Ball Screw Specifications 主要技術參數		End-journal profile 軸端加工形狀	Supported-side 支持側	Fixed-side 固定側
Ball size 鋼珠直徑	$\phi 1.2$	A型	B型	C型
Number of thread 螺紋數	2			
Thread direction 旋轉方向	Right 右旋	<p>L4 : Thread length after end-journal machining. 追加加工後的螺牙長度 L5 : Total length after end-journal machining. 追加加工後的總長度</p>		
Shaft root dia. 螺桿谷徑	$\phi 5.0$	<p>Support-unit Recommendation 推薦的支持座</p> <p>Supported-side 支持側 : MSU-5CS/5GS,SUP04-S Fixed-side 固定側 : MSU-5C/5G,EK5</p>		
Number of circuit 循環數	1.2×2	<p>D型 : 上記以外的形狀</p>		
Material 材質	Shaft 螺桿: SCM415H+SUS303 Nut 螺帽: SCM415H			
Surface hardness 螺紋部表面硬度	HRC58~ (Thread area)			
Anti-rust treatment 防鏽處理	Anti-rust oil 防鏽油			

Unit (單位) : mm

Ball Screw Model 滾珠螺桿型號	Travel 行程	Grade 精度	Shaft length 螺桿長度			Lead accuracy 導程精度		Total Run-out 偏擺量	Axial play 軸向間隙	Preload Torque 預壓扭矩 Nm	Basic Load Rating 基本額定荷重 N	
			L1	L2	L3	Travel deviation 代表移動量誤差 ep	Variation 變動 V300				Dynamic 動額定荷重 Ca	Static 靜額定荷重 Coa
SRT0610-146R220C7	120	Ct7	146	150	220	± 0.02	—	0.080	~0.020	—	950	1600
SRT0610-261R335C7	235	Ct7	261	265	335	± 0.04	—	0.120				
SRT0610-146R220C10	120	Ct10	146	150	220	± 0.10	—	0.160	~0.050			
SRT0610-261R335C10	235	Ct10	261	265	335	± 0.18	—	0.240				

Note) Please refer to P.A-106 for order code of end-journal machining.

註) 追加加工的型號指定方式請參照P.A-106。