

# SRT0812

Shaft dia. (軸徑)  $\phi 8$  Lead (導程) 12mm

Ct7&Ct10

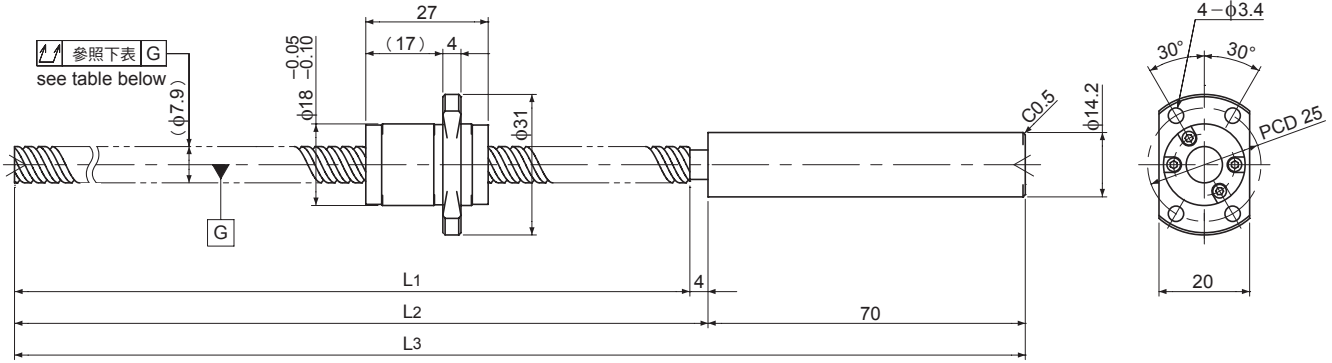

Unit (單位) : mm

Ball Screw Specifications 主要技術參數		End-journal profile 軸端加工形狀	Supported-side 支持側	Fixed-side 固定側
		A型	B型	C型
Ball size 鋼珠直徑	$\phi 1.5875$			
Number of thread 螺紋數	2			
Thread direction 旋轉方向	Right 右旋			
Shaft root dia. 螺桿谷徑	$\phi 6.7$			
Number of circuit 循環數	$1.6 \times 2$			
Material 材質	Shaft 螺桿	SCM415H + SUS303		
	Nut 螺帽	SCM415H		
Surface hardness 螺紋部表面硬度	HRC58~ (Thread area)			
Anti-rust treatment 防鏽處理	Anti-rust oil 防鏽油			
Support-unit Recommendation 推薦的支持座		Supported-side 支持側	MSU-6CS/6GS,EF6	
		Fixed-side 固定側	MSU-6C/6G,EK6	

L4 : Thread length after end-journal machining. 追加加工後的螺牙長度  
L5 : Total length after end-journal machining. 追加加工後的總長度

D-型 : 上記以外の形狀

Unit (單位) : mm

Ball Screw Model 滾珠螺桿型號	Travel 行程	Grade 精度	Shaft length 螺桿長度			Lead accuracy 導程精度		Total Run-out 偏擺量	Axial play 軸向間隙	Preload Torque 預壓扭矩 Nm	Basic Load Rating 基本額定荷重 N	
			L1	L2	L3	Travel deviation 代表移動量誤差 ep	Variation 變動 V300				Dynamic 動額定荷重 Ca	Static 靜額定荷重 Coa
SRT0812-196R270C7	165	Ct7	196	200	270	$\pm 0.03$	—	0.080	~0.020	—	2200	4000
SRT0812-356R430C7	325	Ct7	356	360	430	$\pm 0.06$	0.05	0.120				
SRT0812-196R270C10	165	Ct10	196	200	270	$\pm 0.13$	—	0.160	~0.050	—	2200	4000
SRT0812-356R430C10	325	Ct10	356	360	430	$\pm 0.24$	0.21	0.240				

Note ) Please refer to P.A-106 for order code of end-journal machining.

註) 追加加工的型號指定方式請參照P.A-106。