

# PSRT0401K

Compact Nut 精巧型螺帽

Shaft dia. (軸徑)  $\phi 4$  Lead (導程) 1mm

# C5

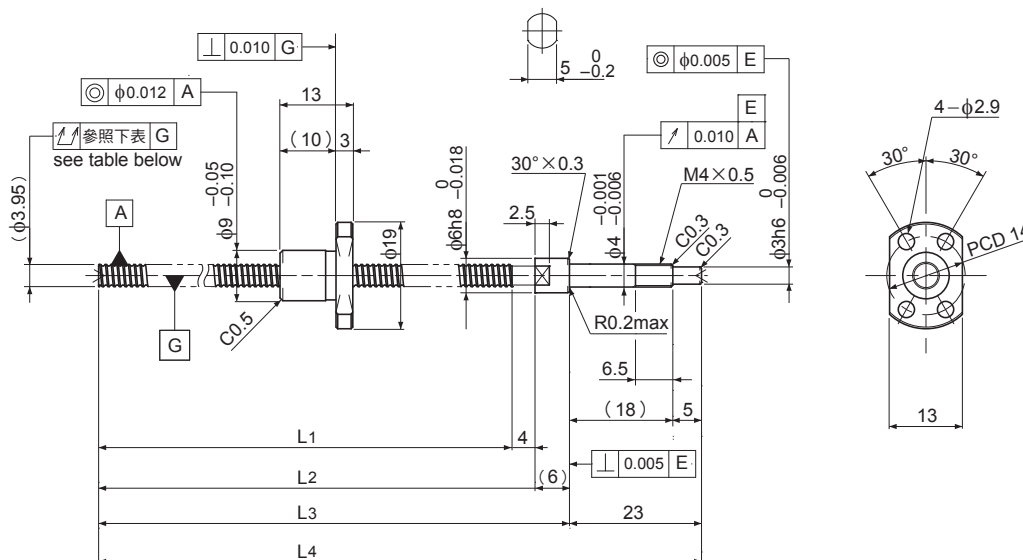

Unit (單位) : mm

Ball Screw Specifications		主要技術參數
Ball size 鋼珠直徑		$\phi 0.6$
Number of thread 螺紋數		1
Thread direction 旋轉方向		Right 右旋
Shaft root dia. 螺桿谷徑		$\phi 3.4$
Number of circuit 循環數		1×3
Material 材質	Shaft 螺桿	S55C + SUS303
	Nut 螺帽	SCM415H
Surface hardness 螺紋部表面硬度		HRC58~ (Thread area)
Lubrication 潤滑油脂		KSS Original Grease MSG No.2

Supported-side end-journal profile 支持側軸端加工形狀

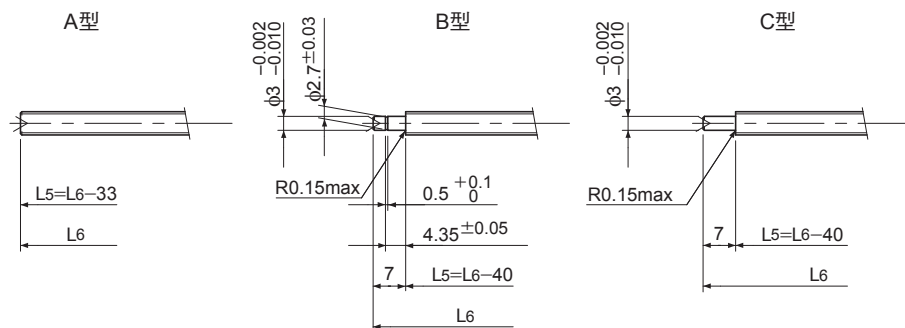

L5 : Thread length after end-journal machining. 追加加工後的螺牙長度  
L6 : Total length after end-journal machining. 追加加工後的總長度

Support-unit Recommendation 推薦的支持座	Supported-side 支持側	Fixed-side 固定側
	MSU-4CS/4GS, SUP03-S	MSU-4C/4G, EK4

D-type : 上記以外の形狀

Unit (單位) : mm

Ball Screw Model 滾珠螺桿型號	Travel 行程	Shaft length 螺桿長度				Travel deviation 代表移動量誤差 $e_p$	Total Run-out 偏擺量 $\uparrow\downarrow$	Axial play 軸向間隙	Basic Load Rating 基本額定荷重 N	
		L1	L2	L3	L4				Dynamic 動額定荷重 Ca	Static 靜額定荷重 Coa
PSRT0401K-72R105C5	50	72	76	82	105	$\pm 0.018$	0.035	$\sim 0.005$	300	430

Note) Please refer to P.A-140 for order code of end-journal machining.

註) 追加加工の型號指定方式請參照P.A-140。