

PSRT0812

Shaft dia. (軸徑) $\phi 8$ Lead (導程) 12mm

C5

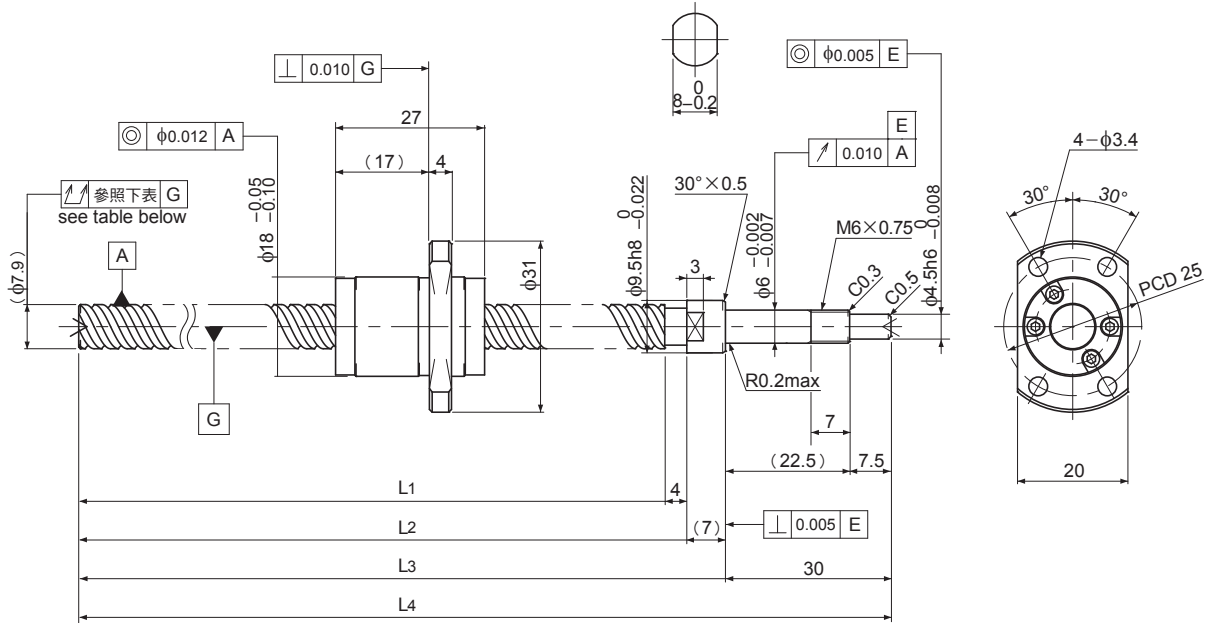

Unit (單位) : mm

Ball Screw Specifications		主要技術參數
Ball size 鋼珠直徑		$\phi 1.5875$
Number of thread 螺紋數		2
Thread direction 旋轉方向		Right 右旋
Shaft root dia. 螺桿谷徑		$\phi 6.7$
Number of circuit 循環數		1.6×2
Material 材質	Shaft 螺桿	S55C + SUS303
	Nut 螺帽	SCM415H
Surface hardness 螺紋部表面硬度		HRC58~ (Thread area)
Lubrication 潤滑油脂		KSS Original Grease MSG No.2

Supported-side end-journal profile

支持側軸端加工形狀

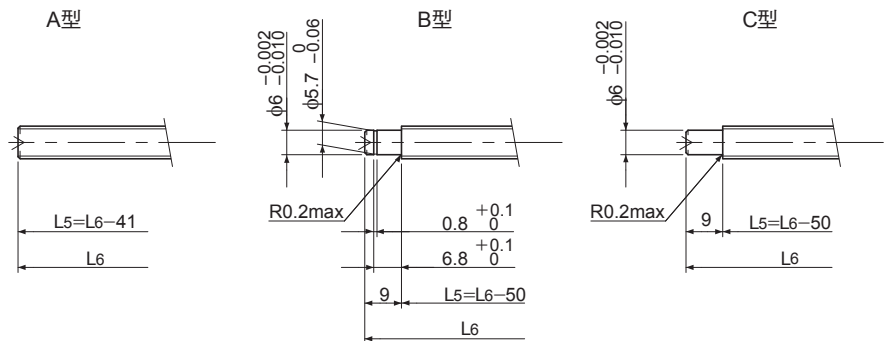

L5 : Thread length after end-journal machining.
L6 : Total length after end-journal machining.

追加加工後的螺牙長度
追加加工後的總長度

Support-unit Recommendation
推薦的支持座

Supported-side 支持側 : MSU-6CS/6GS,EF6
Fixed-side 固定側 : MSU-6C/6G,EK6

D-type : 上記以外の形狀

Unit (單位) : mm

Ball Screw Model 滾珠螺桿型號	Travel 行程	Shaft length 螺桿長度				Travel deviation 代表移動量誤差 e_p	Total Run-out 偏擺量 \updownarrow	Axial play 軸向間隙	Basic Load Rating 基本額定荷重 N	
		L1	L2	L3	L4				Dynamic 動額定荷重 Ca	Static 靜額定荷重 Coa
PSRT0812-169R210C5	135	169	173	180	210	± 0.020	0.065	~ 0.005	2200	4000

Note) Please refer to P.A-140 for order code of end-journal machining.

註) 追加加工的型號指定方式請參照P.A-140。