

Rolled Ball Screw + 5-phase Stepping Motor / 轉造級滾珠螺桿 + 5相步進馬達

TMB0606

Shaft dia. (軸徑) $\phi 6$ Lead (導程) 6mm
Travel (行程) 75mm

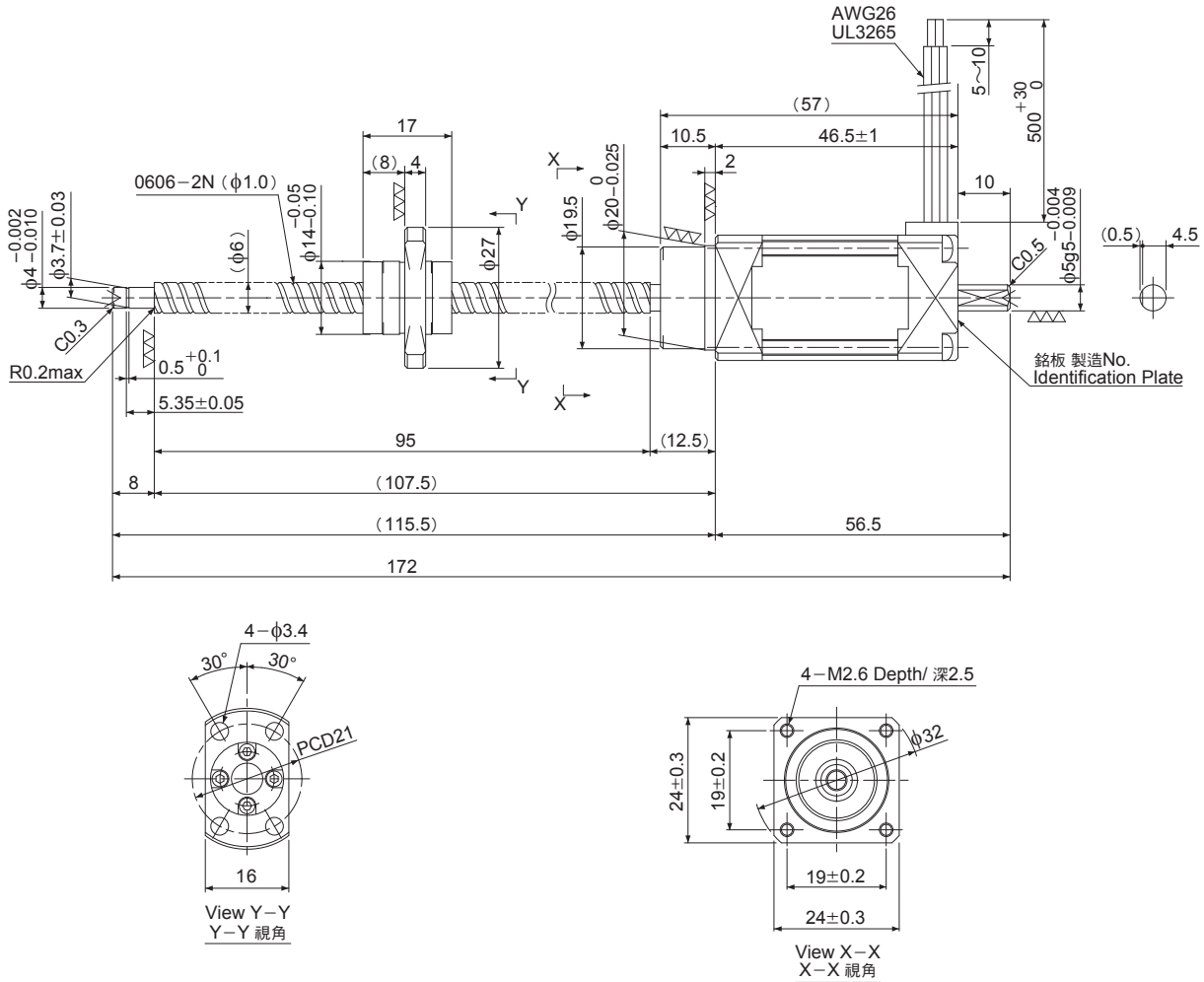

註1) 所推薦的驅動器與其接線圖請參考 P.A-298~A-299

Recommended Drivers 推薦驅動器	KR-A5CC KR-A55MC(Micro step) KR-A535M(Micro step/ AC-100~220V)
------------------------------	--

Recommended accessories 推薦配件	Motor side Supporting plate/ 馬達側支持架	MP-24A或MP-24B
	Supported side Bracket/ 支持側支持架	SP-24
	Nut Block/ 螺帽固定架	NB-0606R

Ball Screw Specifications	主要技術參數
Accuracy grade 精度等級	JIS Ct7
Thread direction 旋轉方向	Right 右旋
Axial play 軸向間隙	0.020mm以下
Reference Thrust 參考推力	15N
Shaft & Nut material 螺桿、螺帽材質	Chrome-molybdenum steel 鉻鉬鋼
Surface Coating 表面處理	Black Chrome coating on Shaft 軸桿黑鉻處理
Surface hardness 螺紋部表面硬度	HRC58~HRC62 (Thread area)
Lubricant 潤滑劑	KSS original grease MSG No.1 KSS原廠潤滑油脂 MSG No.1

Motor Specifications	馬達參數
Basic step angle 基本步進角	0.72°
Rated Voltage 額定電壓	DC 1.28V
Rated current 額定電流	0.75A/ 相
Winding resistance 繞線電阻	1.7 Ω
Holding Torque 保持轉矩	0.028Nm
Rotor inertia 轉子慣量	8.8 g · cm ²
Operating temperature 使用溫度範圍	-20°C~50°C

註2) 可提供螺桿軸端裁切的加工。
軸端裁切以外的加工均屬特殊客製品。