

SG0601

Shaft dia. (軸徑) $\phi 6$ Lead (導程) 1mm

C3&C5

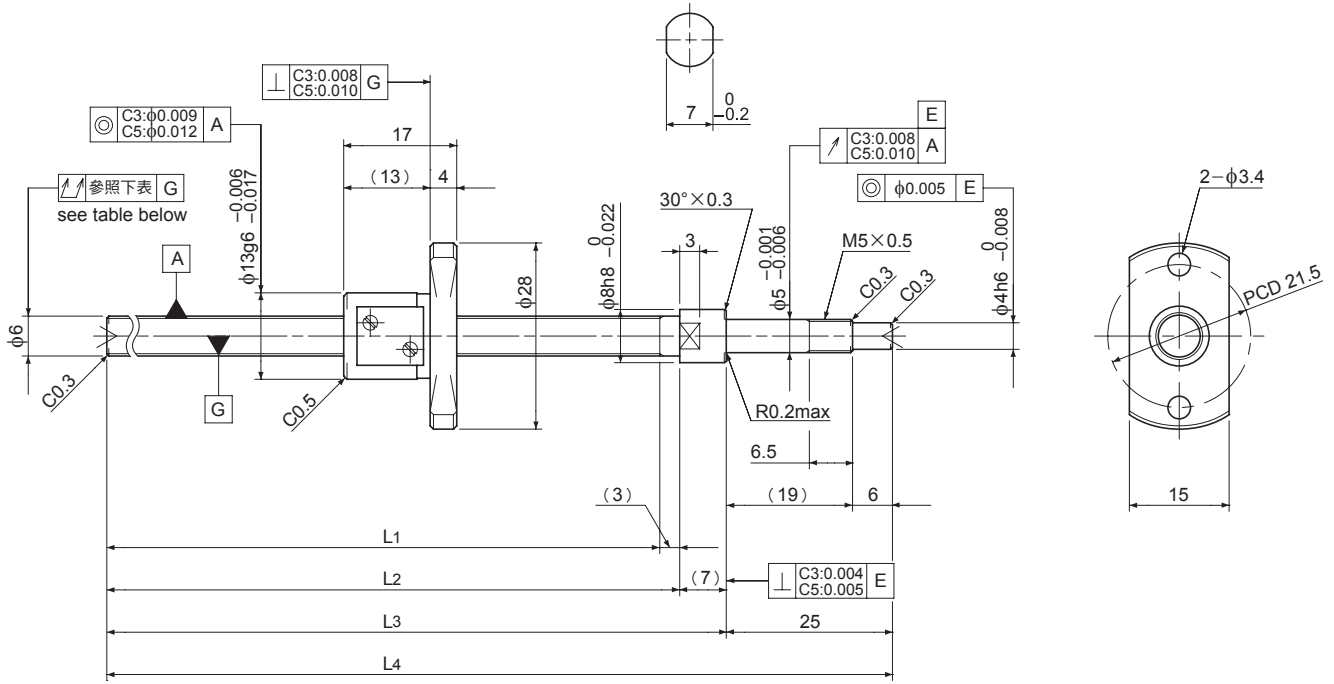

Unit (單位): mm

Ball Screw Specifications	主要技術參數
Ball size 鋼珠直徑	$\phi 0.8$
Number of thread 螺紋數	1
Thread direction 旋轉方向	Right 右旋
Shaft root dia. 螺桿谷徑	$\phi 5.3$
Number of circuit 循環數	3.7×1
Shaft, Nut material 螺桿、螺帽材質	SCM415H
Surface hardness 螺紋部表面硬度	HRC58~62 (Thread area)
Anti-rust treatment 防鏽處理	Anti-rust oil 防鏽油

Supported-side end-journal profile 支持側軸端加工形狀

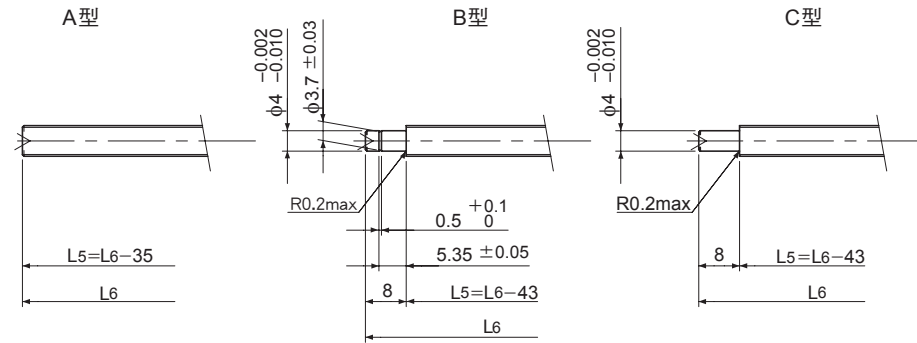

L5: Thread length after end-journal machining. 追加加工後的螺牙長度
L6: Total length after end-journal machining. 追加加工後的總長度

Support-unit Recommendation 推薦的支持座	Supported-side 支持側	Fixed-side 固定側
	MSU-5CS/5GS,SUP04-S	MSU-5C/5G,EK5

D-type: 上記以外の形狀

Unit (單位): mm

Ball Screw Model 滾珠螺桿型號	Travel 行程	Grade 精度	Shaft length 螺桿長度				Lead accuracy 導程精度		Total Run-out 偏擺量	Axial play 軸向間隙	Preload Torque 預壓扭矩 Nm	Basic Load Rating 基本額定荷重 N	
			L1	L2	L3	L4	Travel deviation 代表移動量誤差 e_p	Variation 變動 V_u				Dynamic 動額定荷重 C_a	Static 靜額定荷重 C_oa
SG0601-085R120C3	65	C3	85	88	95	120	± 0.008	0.008	0.025	0 Spacer Ball 間隔鋼珠 (1:1)	~0.006	430	610
SG0601-110R145C3	90	C3	110	113	120	145	± 0.010	0.008	0.035				
SG0601-135R170C3	115	C3	135	138	145	170	± 0.010	0.008	0.035				
SG0601-085R120C5	65	C5	85	88	95	120	± 0.018	0.018	0.035	~0.005	—	680	1200
SG0601-110R145C5	90	C5	110	113	120	145	± 0.020	0.018	0.050				
SG0601-135R170C5	115	C5	135	138	145	170	± 0.020	0.018	0.050				

Note) Please refer to P.A-17 for order code of end-journal machining.

註) 追加加工的型號指定方式請參照P.A-17。