

SG1510

Shaft dia. (軸徑) $\phi 15$ Lead (導程) 10mm

C5

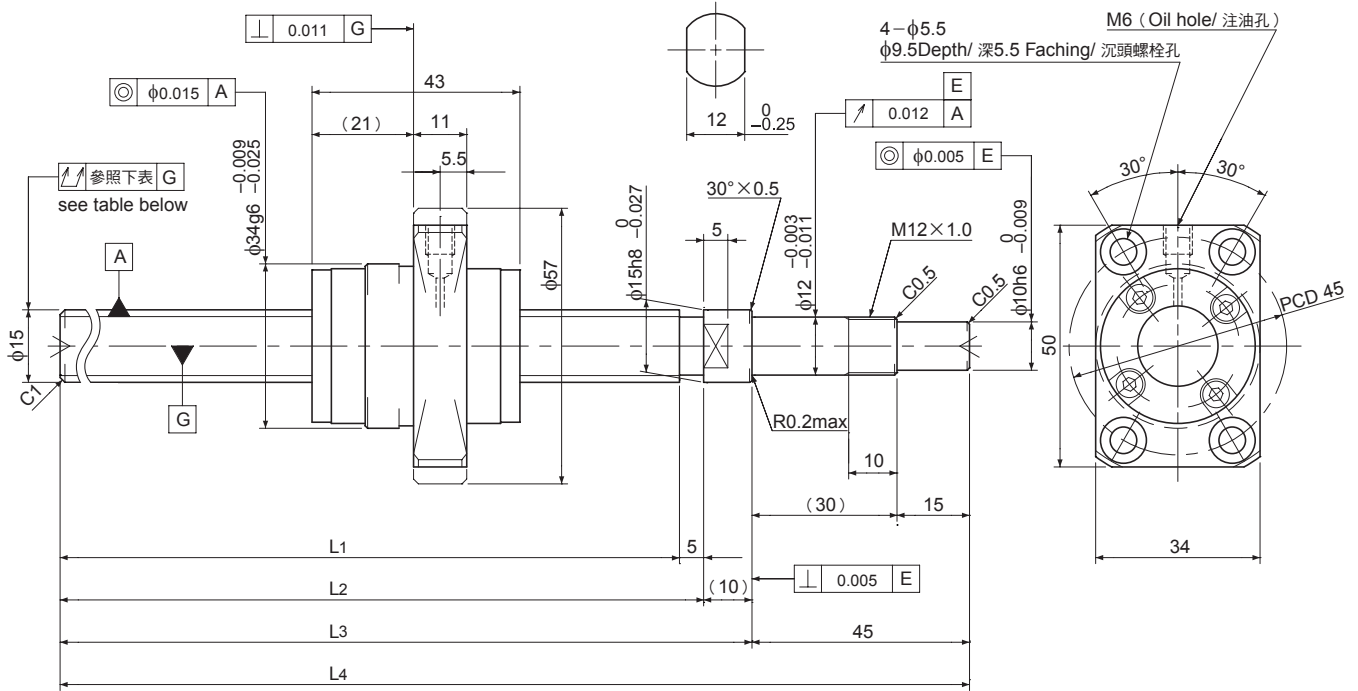

Unit (單位) : mm

Ball Screw Specifications 主要技術參數	
Ball size 鋼珠直徑	$\phi 3.175$
Number of thread 螺紋數	2
Thread direction 旋轉方向	Right 右旋
Shaft root dia. 螺桿谷徑	$\phi 12.2$
Number of circuit 循環數	2.7×2
Shaft, Nut material 螺桿、螺帽材質	SCM415H
Surface hardness 螺紋部表面硬度	HRC58~62 (Thread area)
Anti-rust treatment 防鏽處理	Anti-rust oil 防鏽油

Supported-side end-journal profile 支持側軸端加工形狀

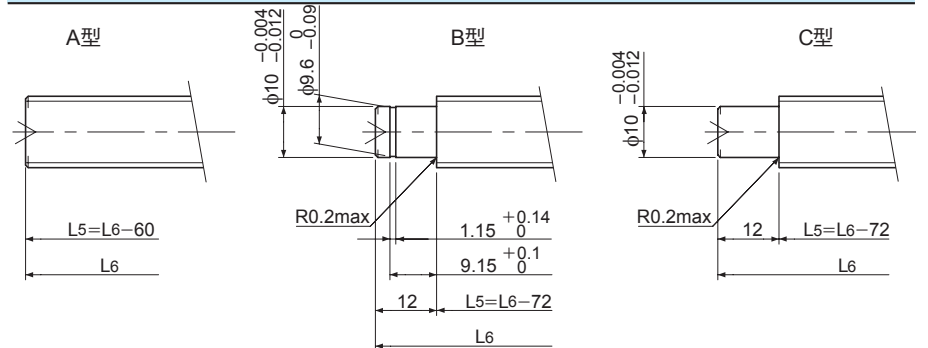

L5 : Thread length after end-journal machining. 追加工後的螺牙長度
L6 : Total length after end-journal machining. 追加工後的總長度

Support-unit Recommendation 推薦的支持座	Supported-side 支持側 : EF12	Fixed-side 固定側 : EK12
------------------------------------	---------------------------	-----------------------

D-型 : 上記以外の形狀

Unit (單位) : mm

Ball Screw Model 滾珠螺桿型號	Travel 行程	Grade 精度	Shaft length 螺桿長度				Lead accuracy 導程精度		Total Run-out 偏擺量	Axial play 軸向間隙	Preload Torque 預壓扭矩 Nm	Basic Load Rating 基本額定荷重 N	
			L1	L2	L3	L4	Travel deviation 代表移動量誤差 ep	Variation 變動 Vu				Dynamic 動額定荷重 Ca	Static 靜額定荷重 Coa
SG1510-340R400C5	295	C5	340	345	355	400	± 0.025	0.020	0.055	~0.005	—	12000	25000
SG1510-540R600C5	495	C5	540	545	555	600	± 0.030	0.023	0.075				

Note) Please refer to P.A-17 for order code of end-journal machining.

註) 追加工的型號指定方式請參照P.A-17。